



Operating manual**Water-Proof oxygen meter for oxygen in gases
with Integrated temperature and pressure
measuring and data logger**

As of version 1.0

ResOx 5695

-  Please carefully read these instructions before use!
-  Please consider the safety instructions!
-  Please keep for future reference!



WEEE-Reg.-Nr. DE 93889386

GHM GROUP - Greisinger

GHM Messtechnik GmbH | Hans-Sachs-Str. 26 | 93128 Regenstauf | GERMANY
 Tel.: +49 9402 9383-0 | info@greisinger.de | www.greisinger.de

Contents

1	SAFETY	3
1.1	GENERAL NOTE.....	3
1.2	INTENDED USE	3
1.3	QUALIFIED STAFF	3
1.4	SAFETY SIGNS AND SYMBOLS.....	3
1.5	REASONABLY FORESEEABLE MISUSE	4
1.6	SAFETY GUIDELINES	4
2	PRODUCT DESCRIPTION	4
2.1	SCOPE OF SUPPLY	4
2.2	OPERATION AND MAINTENANCE ADVICE	5
3	START OF OPERATION	5
4	OPERATION	5
4.1	DISPLAY ELEMENTS.....	5
4.2	PUSHBUTTONS	6
4.3	CONNECTIONS	6
4.4	POP-UP CLIP	7
5	CONFIGURATION	8
6	THE OXYGEN SENSOR	10
6.1	GENERAL NOTES ABOUT THE OXYGEN SENSOR.....	10
6.2	SENSOR ELEMENTS	11
7	OXYGEN MEASURING IN GASES- PLEASE NOTE	11
7.1	APPLICATION OF THE DIFFERENT SENSOR TYPES	11
8	EXCHANGING THE SENSOR ELEMENT	12
9	CALIBRATION OF THE OXYGEN SENSOR	13
9.1	ONE POINT CALIBRATION "CAL 1-PT"	13
9.2	2 / 3- POINT CALIBRATION "CAL 2-PT", "CAL 3-PT"	13
9.3	EVALUATION OF SENSOR STATE "ELEC"	14
10	DATA LOGGER	14
10.1	GENERAL	14
10.2	RECORDING MANUAL "Func Stor"	14
10.3	AUTOMATIC RECORDING WITH SELECTABLE CYCLE TIME "Func CYCL"	15
11	ADJUSTMENT OF TEMPERATURE INPUT	16
12	GLP	16
12.1	CALIBRATION/ADJUSTMENT INTERVAL "Int"	16
12.2	CALIBRATION/ADJUSTMENT MEMORY "rEAd CAL"	16
13	ALARM "AL"	17
14	REAL TIME CLOCK "CLOC"	17
15	UNIVERSAL OUTPUT	17
15.1	INTERFACE	17
15.2	ANALOG OUTPUT	18
16	INSPECTION OF THE ACCURACY/ ADJUSTMENTS AERVICES	19
17	BATTERY CHANGE	19
18	ERROR AND SYSTEM MESSAGES	20
19	RESHIPMENT AND DISPOSAL	21
19.1	RESHIPMENT	21
19.2	DISPOSAL	21
20	SPECIFICATION	21

1 Safety

1.1 General note

Read this document attentively and make yourself familiar to the operation of the device before you use it. Keep this document in a ready-to-hand way in order to be able to look up in the case of doubt. Mounting, start-up, operating, maintenance and removing from operation must be done by qualified, specially trained staff that have carefully read and understood this manual before starting any work. The manufacturer will assume no liability or warranty in case of usage for other purpose than the intended one, ignoring this manual, operating by unqualified staff as well as unauthorized modifications to the device. The manufacturer is not liable for any costs or damages incurred at the user or third parties because of the usage or application of this device, in particular in case of improper use of the device, misuse or malfunction of the connection or of the device. The manufacturer is not liable for misprints.

1.2 Intended use

The instrument is measuring oxygen in air and gas mixtures either as partial pressure or as concentration in % Vol. O₂.

For the measuring an external sensor of the type GOO-..., GGO... or GGA ...is necessary. The measuring take place at the extern opening Sensor.

Due to the properties of the sensor, it has to be calibrated regularly (e.g. at fresh air = 20.95 % Vol. O₂) to get precise values. If the sensor is used up, this will be detected during the calibration, the sensor has to be regenerated or replaced before continuing with measuring. The sensor has to be connected to the 7-pole bayonet socket.

The safety requirements (see below) have to be observed. The device must be used only according to its intended purpose and under suitable conditions.

1.3 Qualified staff

All instructions have to be well understood and complied with. To be sure that there is no risk arising due to misinterpretation of measured values, the operator must have further knowledge in case of doubt - the user is liable for any harm/damage resulting from misinterpretation due to insufficient knowledge.

1.4 Safety signs and symbols

Warning notices are marked in this manual as shown below:



Caution! This symbol warns of imminent danger, death, serious injuries and significant damage to property at non-observance.



Attention! This symbol warns of possible dangers or dangerous situations, which can provoke damage to the device or environment at non-observance.



Note! This symbol points out processes, which can indirectly influence operation or provoke unforeseen reactions at non-observance.

1.5 Reasonably foreseeable misuse



This device **must not be used** at potentially explosive areas!

Do not use these products as safety or emergency stop devices or in any other application where failure of the product could result in personal injury or material damage.

Failure to comply with these instructions could result in death or serious injury and material damage.



This device must not be used at a patient for diagnostic or other medical purpose.

1.6 Safety guidelines

This device has been designed and tested in accordance with the safety regulations for electronic devices. However, its trouble-free operation and reliability cannot be guaranteed unless the standard safety measures and special safety advises given in this manual will be adhered to when using the device.



Trouble-free operation and reliability of the device can only be guaranteed if the device is not subjected to any other climatic conditions than those stated under 20 Specification.

If there is a risk whatsoever involved in running it, the device has to be switched off immediately and to be marked accordingly to avoid re-starting.

Operator safety may be a risk if:

- there is visible damage to the device
- the device is not working as specified
- the device has been stored under unsuitable conditions for a longer time.

In case of doubt, please return device to manufacturer for repair or maintenance.



Internal connections of other devices (e.g. from ground with protective earth) may lead to prohibited voltage levels that could disturb the function, damage or even destruct the device or any connected equipment.

2 Product description

2.1 Scope of supply

The scope of supply includes:

- Handheld instrument ResOx 5695 with 2 AAA-Batteries (oxygen sensor usually is ordered separately. For choice please refer to chapter 6 The oxygen sensor)
- Operating manual
- Short form manual
- Calibration protocol
- Silicone protective cover

2.2 Operation and maintenance advice

Battery operation:

If „**bAt**“ is shown in the lower display the battery has been used up and needs to be replaced. However, the device will operate correctly for a certain time

If „**bAt**“ is shown in the upper display the voltage is too low to operate the device; the battery has been completely used up. Battery change see chapter 17 Battery change.



The battery has to be taken out, when storing device above 50°C. We recommend taking out battery if device is not used for a longer period.
After recommissioning, the real-time clock has to be set again.



Use device and sensor carefully and according to its technical data (do not throw it, strike it, etc.). Protect the device from dirt.

USB or mains operation:

When connecting a mains cable or USB interface cable, please take care to connect only allowed components.



The output voltage of a connected power supply unit has to be between 4.5 and 5.5 V DC. Do not apply overvoltage!

We recommend operation with interface cable USB 5100. Then device is supplied by the USB interface of the connected PC or USB power supply adapter.

3 Start of operation

Connect sensor, switch instrument on with .



After the segment test the instrument shows „**Corr**“ shortly, if it was user adjusted.
The device starts measurement afterwards.

4 Operation

4.1 Display elements



Main display:

- Oxygen concentration in % (% Vol. O₂) or
 - Oxygen partial pressure (hPa or. mmHg)

Choice via  - key

Secondary display:

- sensor temperature or absolute pressure, (alternating, please refer to chapter 5 Configuration „**Lcd.2**“)

3 Main display units

4 State of battery

5 Shows, if minimum/maximum/
memorized measuring value is in display

6 Arrow „ok“: Measured value is stable

7 Arrow „CAL“: Calibration

8 Arrow „Logg“: Logger function is chosen
Is blinking, if cyclic logger is running

9 Arrow „hPa“: Pressure unit of internal sensor

4.2 Pushbuttons

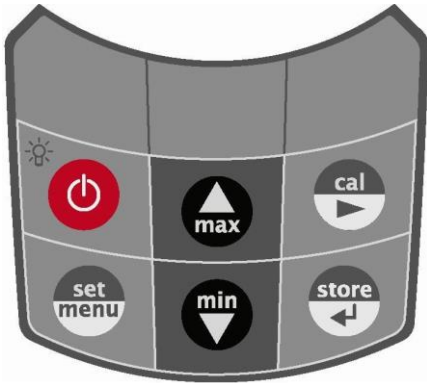

On / off key, backlight

"press shortly":
Activate backlight or switch on instrument
"press longer":
Switch off instrument



Set/Menü

"press for 2 sec" (menu):
Invoke configuration menu
"press shortly":
Change oxygen display unit



min / max

"press shortly":
Min. or max. value is displayed
"press for 2 sec":



The corresponding value is deleted

Configuration

See chapter 5 Configuration:
Confirm settings, return to measuring



Store/Enter

"Measuring":
with Auto-Hold off:
Hold and save current measuring value, ('HLD' is displayed)
with Auto-Hold on:
Start new measuring, It is finished , when "HLD" shows in display please refer to chapter 5 Configuration or calling the logger functions see chapter 10 Data logger



Configuration

See chapter 5 Configuration:
Confirm settings, return to measuring

CAL:

"press shortly":
Shown the sensor state of the last calibration
"press for 2 sec":
Start of the oxygen calibration

4.3 Connections

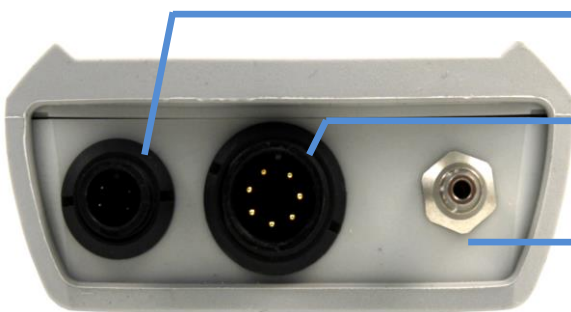

Universal output

Interface, supply, analog output see chapter 15
Universal output

7-pole bayonet socket

Connection for sensor and temperature probe

Pressure Port

Tube Connection for ambient pressure compensation of oxygen sensor.

4.4 Pop-up clip

Handling

- Pull at label “open” in order to swing open the pop-up clip.
- Pull at label “open” again to swing open the pop-up clip further.

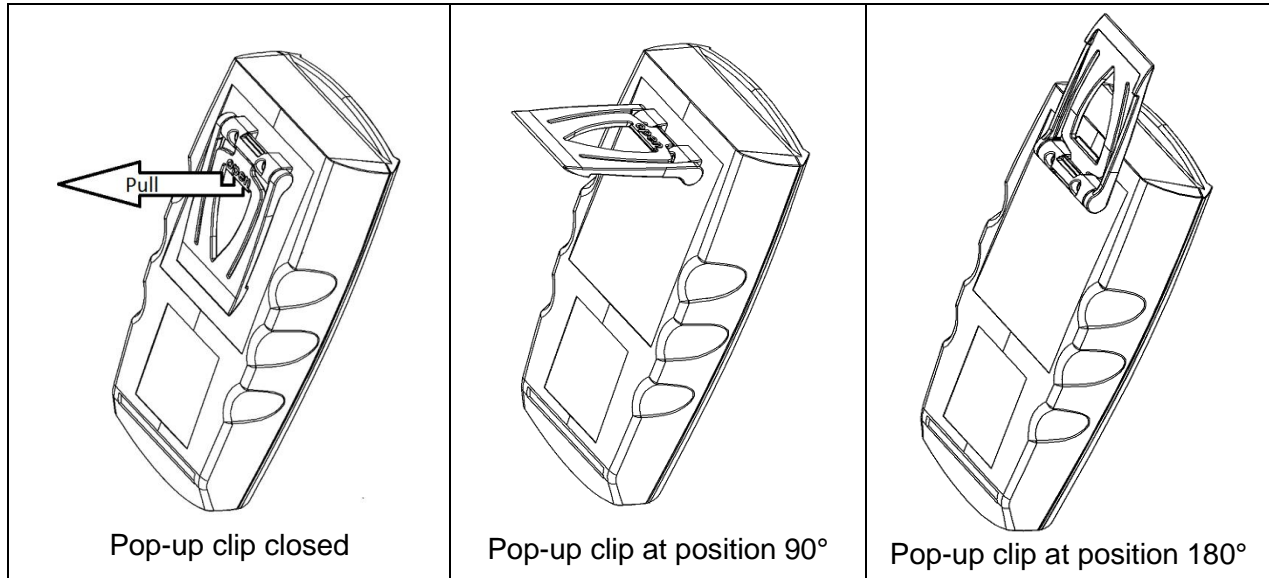

Function:



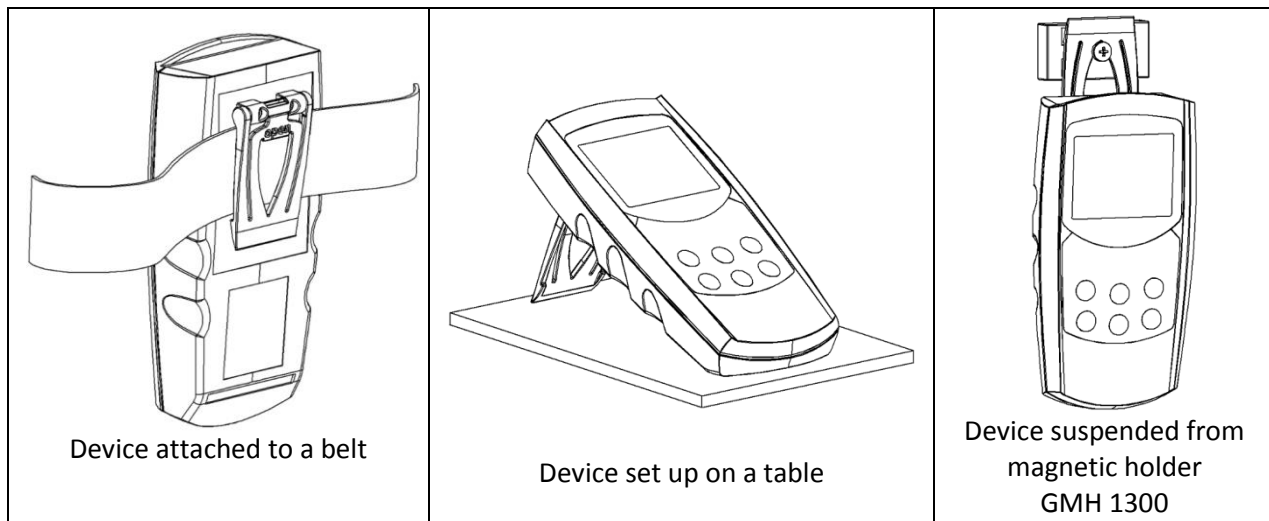

- The device with a closed pop-up clip can be plainly laid onto a table or attached to a belt, etc.
- The device with pop-up clip at position 90° can be set up on a table, etc.
- The device with pop-up clip at position 180° can be suspended from a screw or the magnetic holder GMH 1300.







5 Configuration





Some menu points depend on current device settings (e.g. some points are locked if logger memory contains data sets).

To change device's settings, press  for 2 seconds. This will activate the configuration menu (main display "SEt"). Pressing  changes between the menus points, pressing  jumps to the referring parameters, which can be selected with .





The parameter value can be changed with  or . Pressing  again jumps back to the main configuration menu and saves the settings. Pressing  finishes the configuration.



Pressing  and  at the same time for more than 2 seconds will reset the device to factory defaults.

If there are data sets stored (Logger: "Func Stor"), the first menu point displayed is "rERd Lo66" see chapter 10 Data logger.

If no key is pressed for more than 2 minutes the configuration will be aborted. All changes will be discarded!

Menu	Parameter	Value	Description		
		 or 			see
SEt Conf	Set Configuration: General configuration				9 12
	Ch 2	P 02 hPa	Oxygen partial pressure display in hPa	*	
		P 02 mmHg	Oxygen partial pressure display in mmHg		
	rES	H _i	Best O ₂ resolution		
		L _o	Low O ₂ resolution, calm value display (standard)		
	Lcd.2	t	Secondary display always temperature		
		P	Secondary display always absolute pressure		
		P t	Secondary display alternates between temperature and abs. pressure		
	Unit	°C	All temperatures in degree Celsius (ex works setting)		
		°F	All temperatures in degree Fahrenheit		
	CALP	1-Pt	Simple one point calibration at air		
		2-Pt/ 3-Pt	2 or 3- calibration at air, or in oxygen or in nitrogen / zero gas		
	C. Int	1 ... 365	Calibration reminder period (in days)		
		oFF	No calibration reminder		
	Auto HLD	oN	Auto stable value determining freezing (when logger = off)		
		oFF	Standard hold function on key press (when logger = off)		
	P.oFF	1 ... 120	Power-off delay in minutes. Device will be automatically switched off as soon as this time has elapsed if no key is pressed/no interface communication takes place. (ex works setting 20min)		
		oFF	Automatic power-off function deactivated (continuous operation)		
	L tE	oFF	Backlight Illumination deactivated		
		5...120	Turn off backlight after 5... 120 s (factory settings: 10 s)		
		oN	Backlight always on		
	Out	oFF	Interface off -> minimal power consumption		
		SEr	Serial interface activated (ex works setting)		
		dRC	Analog output activated		

	Adr	01,11,21, ... 91	Base address for serial interface communication (ex works setting 01)		
	dA, n	Conc P.02	Analog output is corresponding to concentration in % Analog output is corresponding to partial pressure in hPa or mmHg		
	dAL0	0.0...100.0 %O ₂	Measuring value that should correspond to output 0 V e.g. for, (ex works setting 0.0 % Vol O ₂)		
	dAL1	0.0...100.0 %O ₂	Measuring value that should correspond to output 1 V e.g. for, (ex works setting 100.0 % Vol O ₂)		
SEt Corr	Set Corr: Input adjustment			**	11
	OFF5 °C bzw. °F	-5.0 °C ... 5.0 °C or -9.0 °F ... 9.0 °F	The zero point of the temperature measuring is shifted for the entered value. This can be used to compensate sensor and instrument deviations	**	
		oFF	No zero adjustment for temperature measurement (=0.0°)		
	SCAL °C bzw. °F	-5.00 ... 5.00 %	The slope of the temperature measurement is corrected by this value. This can be used to compensate sensor and instrument deviations	**	
		oFF	No slope adjustment for temperature measurement (=0.00)		
	OFF5 hPa	-20 ... 20 hPa	The zero point of the pressure measuring is shifted for the entered value. This can be used to compensate sensor deviations	**	
		oFF	No zero adjustment for pressure measurement (=0 hPa)		
SEt AL	Set Alarm: Configuration of the alarm settings				13
	AL 1	on / no.50 oFF	Monitoring oxygen: Alarm on with buzzer / Alarm on without buzzer No alarm monitoring for oxygen		
	AL, n	Conc P.02	Monitoring oxygen: Concentration in % Vol O ₂ Monitoring oxygen: Partial pressure in hPa or mmHg		
	ALLo	e.g. 0.0...100.0 %	Min alarm limit oxygen (not if AL. 1. oFF)		
	ALh	e.g. 0.0...100.0 %	Max alarm limit oxygen (not if AL. 1. oFF)		
	AL 2	on / no.50 oFF	Temperature monitoring : Alarm on with buzzer / Alarm on without buzzer No alarm monitoring for temperature		
	ALLo	-5.0 ... +50.0 °C	Min alarm limit temperature (not if AL. 2. oFF)		
	ALh	-5.0 ... +50.0 °C	Max alarm limit temperature (not if AL. 2. oFF)		
SEt Lo66	Set Logger: Configuration of the logger functions				10.3
	Func	CYCL Stor oFF	Cyclic: Automatic logger function Store: manual recording No logger activated	*	
	CYCL	0:01 ... 60:00	Cycle time in [minutes: seconds] for cyclic logger	**	
SEt CLOC	Set Clock: Configuration of the real time				14
	CLOC	HH:MM	Clock: set time hours: minutes		
	YEAR	YYYY	Year: set year		
	DATE	TT.MM	Date: set date day: month		



(*) If logger memory contains data sets parameters marked with (*) cannot be called. You have to clear memory to change these parameters!

(**) If logger is running parameters marked with (**) cannot be called

6 The oxygen sensor

6.1 General notes about the oxygen sensor

6.1.1 Life time

At the end of the life time, the signal of the sensor is dropping rapidly. The sensor evaluation in % therefore can only be taken as a relative measure. An evaluation of 70% does not mean that 70% of life time is left, but that the electrode signal has 70% of an optimal state reference.

The nominal life time may be reduced due to the application. Negative effects are:

- Extreme storage and operation temperature.
- Humidity of measured gas: If permanently used with dry gases (technical gases, bottled gas) the lifetime decreases considerably.



The sensor state evaluation will be stored after a successful calibration of the oxygen sensor.

6.1.2 Mounting /operation position

The optimum position for the sensor membrane is to point downwards.



If sensor is screwd in pressure.tight into an application wichs pressure differs from the ambient pressure, the maximum differential pressure at the sensor membrane is 250 bar.

6.1.3 Measuring precision

The precision can be influenced due to:

- Liquids at the sensor inlet. Rinse the inlet and dry with lint-free cloth.



Avoid liquids of any kind at the contacts.

- Gas and sensor temperature have to be at same level. Best precision, when calibrated at measuring temperature.
- Pressure fluctuations: The sensor is originally a partial pressure sensor, i.e. changes in the absolute pressure are influencing the measuring result directly proportional. A pressure change of 1% will cause a additional measuring error of 1%!
For optimum precision calibrate at the same conditions at which you want to measure.

6.2 Sensor elements



Unsuitable for underwater-diving-application e.g. Rebreather.

6.2.1 GOEL 370 acidic electrolyte



Integrated in GGO 570, GGA 570, GOO 570.

Recommended application areas 0...35 Vol. % O₂ (above, the measuring accuracy is reduced).

Also suitable for gases with high CO₂-proportion or for CO₂-gas. The effect of the acidic electrolyte is that the sensor is resistant against the CO₂-gas and still hold the stability.

6.2.2 GOEL 381 basic electrolyte



Short-time exposition of up to 10% CO₂ is not problematic (for example 15 minutes. up to 10 times per day) for the GOEL 380 (e.g. exhaust measuring). If there is measured more often with elevated CO₂-concentration or at CO₂-concentrations above 10%, the exposition time has to be kept as short as possible and sufficient measuring breaks should be made.

If the sensor is not exposed to free air during measuring pauses, the connected tubes etc. have to be flushed with clean air or nitrogen.

Integrated in GGO 581, GGA 581, GOO 581.

Recommended application areas 0...100 Vol. % O₂.

Preferred of measurements with extremely small oxygen content (e.g. < 0.3 Vol. % O₂), e.g. protective atmosphere, or more than 35 % Vol O₂.



For gases without larger CO₂ concentration

7 Oxygen measuring in gases- please note

The instrument is designed for measuring the oxygen partial pressure or the oxygen concentration (% Vol. O₂) calculated from partial pressure and ambient pressure) in gases. Please keep in mind.

The sensor consists of a sensing element (GOEL 3xx) enclosed in a sensor housing (GGO/ GGA/ GOO). When purchasing a Sensor GGO/GGA/GOO 5xx, a sensor element is already integrated, e.g. a GGO 570: contains housing GGO and a sensor element GOEL 370

7.1 Application of the different sensor types

7.1.1 GGO housing (closed sensor)

For measurements at atmosphere and in systems without over or under pressure, the GGO... is sufficient.



Additionally the GGO can be screwed tightly into systems with small over or under pressure.

Attention! Mind the maximum pressure and the maximum pressure difference at the membrane.

If instrument and sensor pressure are different, please connect the pressure port of instrument to measuring pressure, otherwise it will

be compensated wrong!

7.1.2 GOO housing (open sensor)



The sensor is equipped with drillings at the end and because of its special construction the measuring gas streams optimally around the sensor. No pressure can appear while gas blows to the sensor, which otherwise would result in erroneous measures. The temperature compensation speed of the sensor also is optimised by this design.

Especially the measuring of gases from compressed gas bottles, where the expansion of the gas leaving the bottle lowers the temperature, is optimised with regard to the temperature compensation and pressure errors. The gas flow should be chosen in a suitable range, where no overpressure can happen, esp. if the sensor is connected directly to the source e.g. by means of a tube.

7.1.3 GGA housing (closed sensor with pressure port)



Especially at **systems with over or under pressure** or at dynamic pressure due to gas flow this type is optimal. It can be screwed tightly into systems with small over or under pressure.

Attention! Mind the maximum pressure.

The instrument pressure port is connected directly to the sensor port. Then the actual pressure at the membrane will be measured and

compensated automatically.

7.1.4 GOG housing (ResOx measuring)



The GOG / ResOx housings are specialized gas sampling devices, which are suitable to sample and analyse small gasprobes by means of a gas sampling pump.

You get more informations in the referring GOG und ResOx set manuals

8 Exchanging the sensor element

The sensor housings are consisting of two halves (1) and (4) and can be opened by screwing up:

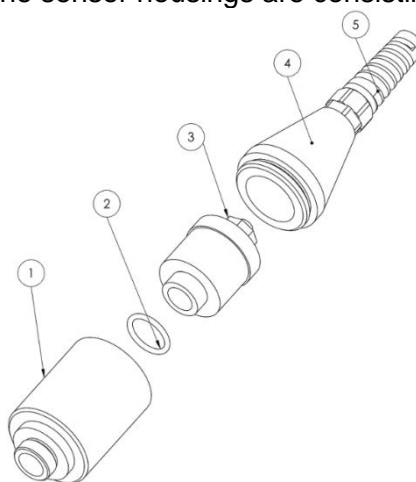

GGO/GGA housing

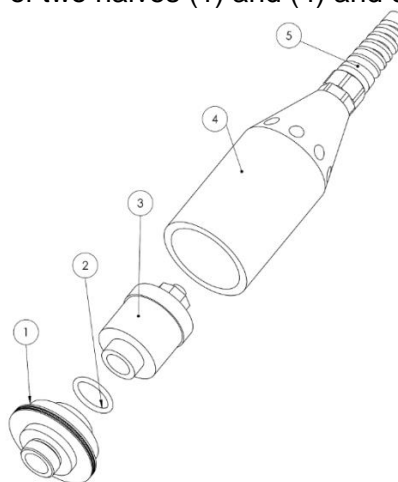

GOO housing

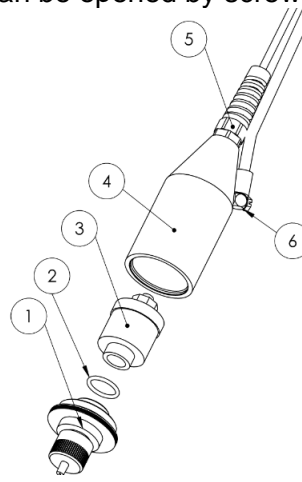

GOG / ResOx 5695 housing

Changeable part is the sensor element (3). Important when reassembling:

- First screw in sensor (3) in part (1). Do not forget O-Ring (2)
Unscrew the sensor carefully e.g. by means of suitable nippers.
- The audio plug of part (4) has to be connected to the socket in the sensor. If this makes problems, the cable gland (5) can be opened so that the cable can be shifted further into part (4), until the plug can be connected.
- After that screw together (1) and (4) tightly, if necessary retighten the cable gland (5).

9 Calibration of the oxygen sensor



In order to compensate for ageing of the sensor, the sensor has to be calibrated at regular intervals.

The device is equipped with an easy-to-use calibration function.

We recommend to calibrate the sensor at least all 7 days, or to get maximum precision, before each measuring series.

9.1 One point calibration "CAL 1-Pt"

The calibration adjusts the sensor to the oxygen content of the atmosphere (20.95 % Vol. O₂) Therefore simply expose the sensor to the ambient air (sufficient ventilation in closed rooms has to be ensured).

Start calibration: press  for 2 seconds.

The display will show **Rr Pt. 1**, and as soon the values for oxygen and temperature are stable, the calibration will be finished.

Then the sensor state resulting of the successful calibration will be shown for a short time evaluation in 10% steps "xx% ELEC".

9.2 2 / 3- Point calibration "CAL 2-Pt", "CAL 3-Pt"

The sensor will be automatically calibrated to the oxygen content of the atmosphere (20.95 % Vol. O₂), and one or two additional concentrations. As reference, gases usually Nitrogen (0 % Vol. O₂) or pure oxygen are used (100 % Vol. O₂).

1. **Start calibration: press:  - key for 2 seconds.**
2. **First calibration reference: (Pt.1)**

As first reference at a 3-point calibration, the zero reference has to be applied 0 % VOL O₂.
at a 2-point calibration either 100 % Vol. O₂ or 0 % Vol. O₂.

The display will show **Pt. 1**, and the referring reference which should be applied.

- **0.2** for pure oxygen.

- **nULL** for 0% oxygen (e. g. pure nitrogen).

As long as the display blinks, the instrument recognises no valid reference.

As soon the values for oxygen and temperature are stable, the calibration of the first point will be finished.

The instrument tells you to apply the next reference (possible references are blinking in the display).

3. **Second calibration reference: (Pt.2)**

The display will show **Pt.2**, and the referring reference which should be applied.

- **Rr** for ambient air.

- **0.2** for pure oxygen.

- **nULL** for 0 % oxygen. (e. g. pure nitrogen).

As long as the display blinks, no valid reference is recognised by the instrument.

As soon the values for oxygen and temperature are stable, the calibration of the second point will be finished.

At 2-point calibration the calibration will be finished and the sensor state resulting of the successful calibration will be shown for a short time evaluation in 10% steps "xx% ELEC".

At 3-point calibration, the instrument tells you to apply the next reference (possible reference is blinking).

1. **Third calibration reference: (Pt.3)**

The display will show **Pt.3**, and the referring reference which should be applied:

As soon the values for oxygen and temperature are stable, the calibration of the second point will be finished.

At 2-point calibration the calibration will be finished and the sensor state resulting of the successful calibration will be shown for a short time evaluation in 10% steps "xx% ELEC".



In case of error messages being displayed during the calibration process, please refer to our notes at the end of this manual! If a calibration cannot be carried out after an extended period of time, at least one of the measuring values is unstable (oxygen partial pressure, temperature).

Please check your measuring arrangements!

9.3 Evaluation of sensor state "ELEC"

Watch sensor state: press  shortly once, display shows "xx% ELEC" for a short time.

This shows the sensor state resulting of the last successful calibration carried out.

The evaluation is displayed in 10 % steps: 100% means optimal sensor condition. Lower values are indicating that the sensor life time will be reached soon.



But also an erroneous pressure may be the cause of low valuation values.

10 Data logger

10.1 General

The device supports two different logger functions:

- "Func Stor": Manual recording by key press . Additional input of measuring point (L-Id) is needed.
- "Func CYCL": Automatic recording at intervals of set cycle time.

A recording consists:

- Oxygen concentration in Vol. O₂ or ppm.
- Oxygen saturation in % oder oxygen partial pressure in hPa or mmHg.
- Temperature in °C oder °F.
- Absolute pressure in hPa abs oder mmHg abs.
- Measuring point L-Id (nur bei "Func Stor").
- Time and date of the recording.





For the evaluation of the data the software GSOF3050 (version V3.0 or higher) has to be used. The software also allows easy configuration and starting of the logger.

When the logger is activated ("Func Stor" or "Func CYCL") the hold function is no more available, the key "store" is solely used for the operation of the logger functions.

10.2 Recording manual "Func Stor"



10.2.1 Recording the measured values manually



1000 measurements can be saved if the logger function "Func Stor" where chosen, see chapter 5 Configuration.

	Press shortly: Recording is stored. It will be displayed for a short time "St. XX" XX represents the number of the recording.
 or 	Measuring point choice
<input type="checkbox"/>	A number of 0...19999 or text, who is assigned to a measurement point number of 1...40, (comfortable assignment of texts can be done with gratis software GMHKonfig)
	Confirm input
	Logger memory full

10.2.2 Call manual recording



Saved recording can be selected with PC-Software GSOF3050, also considered in the display device.

 **Press 2 seconds:** The display is shown: 
 If recording are saved  is appeared. Without recording the configuration menu

  is appeared.







 Last recording

Press again Change between the data of the recording (O₂-concentrate, O₂-parial pressure, absolute pressure, date and time)

 or  Changing the measurement

10.2.3 Delete manual recording

If there are data saved, they could be deleted by pressing the button store:

	Press 2 seconds: Call "delete-menu"
Change the recording:  or 	
	Clear nothing (cancel menu)
	Clear all recordings
	Clear the last recording
	Confirm the selection, end "delete-menu"



10.3 Automatic recording with selectable cycle time "Func CYCL"

If the logger function "Func CYCL" is chosen, after the start, the logger automatically records at the adjusted cycle time.







The logger cycle time is adjustable from 1 s to 60 min, see chapter 5 Configuration.

Storable records: 10000.

10.3.1 Start logger recording

	Press 2 seconds: Start selection
After that, press again  : automatic recording is starting.	
Whenever a measuring is recorded the display shows 'St.XXXXX'.	
XXXXX is the number of the measuring. If the logger memory is full, the display will show 	
The recording automatically will be stopped.	







10.3.2 Stopping the recording manually

	Press 2 seconds: If there runs an recording, "stopp-menu" is shown.
Change the selection:  or 	
	Do not stop the recording (cancel menu)
	Stop the recording
	Confirm the selection, end "stopp-menu"



If you try to switch off the instrument in the cyclic recording operation you will be asked once again if the recording should be stopped.
 The device can only be switched off after the recording has been stopped!
 The Auto-Power-Off-function is deactivated during recording!

10.3.3 Clear recordings

	Press 2 seconds: If there are datas available, and the recording is stopped, "delete-menu" is shown
Change the selection:  or 	
	Clear nothing (cancel menu)
	Clear all recordings
	Delete the last recording
	Confirm the selection, end "delete-menu"

11 Adjustment of temperature input

The temperature input can be adjusted with offset and scale. A reasonable adjustment presumes reliable references (e.g. ice water, controlled precision water bath, etc.). If the inputs are adjusted (i.e. offset and scale are different from default settings) the device will shortly display "Corr" after turned on. Default setting for offset and scale are 'off' = 0.0, i.e. inputs are not changed.

Zero point correction: Displayed value = measured value **OFFS**.

Zero point and slope correction: Displayed value = (measured value - **OFFS**) • (1 + **SCAL** / 100).
 Displayed value °F = (meas. value °F - 32°F - **OFFS**) (1 + **SCAL** /100).

12 GLP

GLP (Good Laboratory Practice) includes regular check of devices and accessories. For oxygen measurements, it is highly important to ensure correct sensor calibration/adjustment. The device provides the following functions to help with this.

12.1 Calibration/Adjustment interval "Int"

You can input the interval after which the device reminds you to recalibrate.

The interval times should be chosen according to the application and the stability of the sensor „CAL“ flashes on the display as soon as the interval has expired.

12.2 Calibration/Adjustment memory "rEAd CAL"

The last 16 calibrations are stored with results, date, and can be read out.

12.2.1 Show Memory

Historical calibration data can be comfortably read out via PC software GMHKonfig and GSOFT3050 or displayed directly at the device:



Press for 2 seconds:

The display will show

oder

(configuration level)



Press several times until this is

displayed:

rEAd CAL = " read calibration data "



Press shortly: switch between::

- **ELEC** = Overall evaluation in %
- **SL.1** = Slope 0% - Air *¹⁾
- **SL.2** = Slope Air – 100%*¹⁾
- Display of date+time of data set



or



Change between the different calibration data sets



Quit calibration data set display

*¹⁾at the 1 and 2-Punkt-calibration is SL.1 = SL. 2

at 3-point calibration there are independent slope for the two segments.

13 Alarm "AL"

There are 3 possible settings:

off "AL_oFF", on with buzzer "AL_on", on without buzzer "AL_ono.5o".

Alarm is given in the following cases if alarm active (on or no.5o):

- Lower alarm boundary (AL_lo) under-run
- Upper alarm boundary (AL_lh,) over-rum.
- Sensor error.
- Low battery (bALt)
- Err.7: system error (always with buzzer).

In case of an alarm and when polling the interface the ,PRIO-flag is set in the returned interface message.

14 Real time clock "CLOC"

The real time clock is used for chronological assignment of the logger data and calibration points. Please check the settings when necessary.

15 Universal output

The output can be used as serial interface (for USB5100 interface converter). If the output is not needed, it is strongly recommended to deactivate it (Out oFF), to lower power consumption. This increases battery life time.

If the device is used together with interface adapter USB 5100 the device is supplied from the interface
device pin assignment

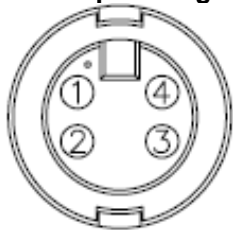

- 1: external supply +5V, 50mA
- 2: GND
- 3: TxD/RxD (3.3V Logic)
- 4: +UDAC, analog output



Only suitable adaptor cables are permitted (accessories)!

15.1 Interface

The device can be directly connected to a PC at the USB interface, with an electrically isolated interface converter USB 5100 (accessory). The transfer takes place via a binary coded format and is protected for transmission errors, by elaborated security mechanisms.

The following standard software packages are available:

- **GSOFT3050:** Operating and evaluation software for the integrated logger function
- **EBS20M / -60M:** 20-/60-channel software for measuring value display
- **GMHKonfig:** Configuration Software (for free on internet)

In case you want to develop your own software, we offer a **GMH3000- development package** including:

- a universally applicable Windows functions library ('GMH3000.DLL') with documentation, can be used by all 'established' programming languages, suitable for, Windows XP™, Windows Vista™, Windows 7™, Windows 8 / 8.1™, Windows 10™
- Programming examples Visual Studio 2010 (C#, C++ und VB), Testpoint™, LabVIEW™ etc.

The device has 4 channels:

- Oxygen concentration in % Vol. O₂.
- Oxygen partial pressure in hPa or mmHg.
- Temperature value at the time of recording in °C or °F.
- Absolute pressure in hPa abs or mmHg abs.

15.1.1 Supported interface-functions:

1	2	3	4	Code	Name/Function	1	2	3	4	Code	Name/Function
x	x	x	x	0	read nominal value	x	x	x	x	199	read measuring type in display
x	x	x	x	3	read system status	x	x	x	x	200	read min. display range
x				12	read ID-no.	x	x	x	x	201	read max. display range
x	x	x		22	read min alarm limit	x	x	x	x	202	read unit of display
x	x	x		23	read max alarm limit	x	x	x	x	204	read decimal point of display
x	x	x	x	176	read min. measuring range	x				208	read channel count
x	x	x	x	177	read max. measuring range	x				222	read turn-off-delay
x	x	x	x	178	read measuring range unit	x				223	Set turn-off-delay
x	x	x	x	179	read measuring range decimal point	x				240	Reset
x	x	x	x	180	read measuring type	x				254	read program identification



The measuring and range values read via interface are always in the selected display unit!

15.2 Analog output

An analog voltage 0-1 V can be tapped at the universal output socket (mode: "Out dAC"). The analog output can be easily scaled with DAC.0 and DAC.1).

Please take care not to load the analog output too heavily, otherwise the output value will be distorted and the power consumption will rise. Loads up to approx. 10 kOhm are unproblematic.

If the displayed value goes beyond DAC.1 the output voltage will be 1V.

If the displayed value falls below DAC.0 the output voltage will be 0V.

In error case (Err.1, Err.2, ----, etc.) the output voltage will be slightly higher than 1V.

16 Inspection of the accuracy/ adjustments aervices

The instrument can be sent to the manufacturer for adjustment and function test.
Only the manufacturer can check all systems on correct them if necessary.

Calibration certificates – DKD-certificates – other certificates:

There it is actually not possible to certificate the device for solved oxygen measurement, only for temperature and pressure measurement.

17 Battery change

Before changing batteries, please read the following instruction and follow it step by step.

Not following the instruction may cause harm to the instrument or the protection against ingress of water and dust may be lost!

Avoid unnecessary opening of the instrument!





1. Open the 3 Phillips screws at the backside of the instrument.
2. Lay down the still closed instrument, so that the display side points upwards.
The lower half of the housing incl. the electronics should be kept lying down during battery change.
This avoids loss of the 3 sealing rings placed in the screw holes.
3. Lift off upper half of housing. Keep an eye on the six function keys, to be sure not to damage them.
4. Change carefully the two batteries (Type: AAA).
5. Check: Are the 3 sealing rings placed in the housing?
Is the circumference seal of the upper half sound and clean?

Close the housing, taking care that it is positioned correctly, otherwise the sealing may be damaged. Afterwards press the two halves together, lay the instrument with display pointing downwards and screw it together again

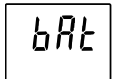

Take care to screw only until you feel increasing resistance, higher screwing force does not result in higher water protection!

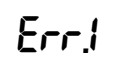
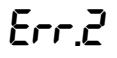





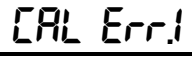
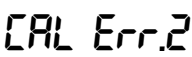

18 Error and System Messages

Display	Meaning	Remedy
	low battery voltage, device will continue to work for a short time	replace battery
	If mains operation: wrong voltage	replace power supply, if fault continues to exist: device damaged
	low battery voltage	replace battery
	If mains operation: wrong voltage	Check/replace power supply, if fault continues to exist: device damaged
No display or weird display	low battery voltage	replace battery
	If mains operation: wrong voltage	check/replace power supply, if fault continues to exist: device damaged
Device does not react on keys	system error	disconnect battery or power supply, wait some time, re-connect
	device defective	return to manufacturer for repair
	sensor error: no sensor cable connected	connect suitable sensor
	Sensor, cable or instrument defect	return to manufacturer for repair
	Value exceeding measuring range	Check: Is the value exceeding the specified measuring range? ->value too high!
	Wrong sensor connected	Check sensor
	Sensor, cable or instrument defect	return to manufacturer for repair
	Value below display range	Check: Is the value below the specified measuring range? ->value too low!
	Wrong sensor connected	Check sensor
	Sensor, cable or instrument defect	return to manufacturer for repair
	system error	return to manufacturer for repair

If "bAt" is flashing, the battery will be exhausted soon. Further measurements are possible for short time.

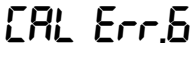
If "bAt" is displayed continuously the battery is ultimately exhausted and has to be replaced. Further measurements aren't possible any more.

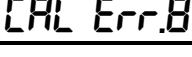
Messages During Calibration/Adjustment

	either preset calibration interval has expired or last calibration is not valid	device has to be calibrated!
	wrong reference point at air	check sensor and reference gas
	slope too low	
	reference gas wrong	check sensor and reference gas
	sensor element is defect	replace sensor element
	slope too high	
	reference gas wrong	check sensor and reference gas
	sensor element is defect	replace sensor element
	incorrect calibration temperature	calibration can only be done at 0...50 °C
	Zero value to low/negative	
	sensor element is defect	replace sensor element
	zero value to high	
	reference gas wrong	check sensor and reference gas
	sensor element is defect	replace sensor element
	incorrect calibration pressure	check calibration pressure
	signal not stable / timeout	check sensor and reference gas
	sensor not known: cannot be calibrated	check sensor and wiring

19 Reshipment and disposal

19.1 Reshipment



All devices returned to the manufacturer have to be free of any residual of measuring media and other hazardous substances. Measuring residuals at housing or sensor may be a risk for persons or environment



Use an adequate transport package for reshipment, especially for fully functional de-vices. Please make sure that the device is protected in the package by enough pack-ing materials.

Add the completed reshipment form of the GHM website <http://www.ghm-messtechnik.de/downloads/ghm-formulare.html>.

19.2 Disposal



The device must not be disposed in the unsorted municipal waste! Send the device directly to us (sufficiently stamped), considering the above if it should be disposed. We will dispose the device appropriate and environmentally sound

20 Specification

Measuring ranges	O ₂ - concentration	[Lo] 0.0 ... 100.0 % Vol.O ₂ [Hi] 0.00...100.00 % Vol.O ₂	electrochemical sensors GGO / GOO / GGA
	O ₂ - partial pressure	[Lo] -0 ... 1100 hPa O ₂ [Hi] -0.0 ... 1100.0 hPa O ₂	“ “ “
	Sensor temperature	-5,0 ... + 50,0 °C	NTC 10k (integrated in GGO / GOO / GGA cable)
	Absolute pressure	300 ... 5000 hPa abs.	integrated pressure sensor with pressure port
Accuracy (instrument without sensor , nominal temperature, 1000 hPa abs)	O ₂	±0.1 % Vol. O ₂	
	O ₂ - partial pressure	± 1 hPa	
	Sensor temperature	± 0.1 °C	
Accuracy	Absolute pressure	3 hPa or 0.1% of measured value (the higher one to be applied)	
Working conditions	-20 ... 50 °C; 0 ... 95 % r.H. (not condensing, sensor min -5°C)		
Nom. temperature	25 °C		
Storage temp.	-25 ... 70 °C (Sensor min -5 °C)		
Connections	O ₂ & temperature	6 pole waterproof bayonet connector	
	Absolute pressure	Universal pressure port for tubes with 4 or 6mm inner-Ø	
	Interface / Analogue output / external supply	4 pole waterproof bayonet connector (USB adapter USB 5100)	
Display	LCD, white backlight, two 4½ digits 7-segment (main and auxiliary display) with additional symbols		
Calibration	automatic	1 -, 2- or 3-point calibration, 0%, 100% or ambient air (20.95% Vol. O ₂)	
Alarm	Buzzer / visual / interface 2 channels: selectable oxygen unit and temperature		
Additional functions	Min / max / hold / auto hold		
Data logger	Real-time clock Cyclic: 10000 data sets, cycle time 1s to 60 minutes Single: 1000 data sets, with measuring point input		
GLP	calibration memory adjustable calibration intervals (1 to 365 days, CAL warning after expiration)		

Housing <table border="1" style="width: 100%; border-collapse: collapse;"> <tr> <td style="width: 20%;">Protection class</td> <td>IP65 / IP67</td> </tr> <tr> <td>Dimensions L*W*H [mm]</td> <td>Without pressure connection: 160 * 86 * 37 incl. silicone protective cover, pressure connection: length 11mm</td> </tr> <tr> <td>Weight</td> <td>approx. 250 g incl. battery and cover</td> </tr> </table>	Protection class	IP65 / IP67	Dimensions L*W*H [mm]	Without pressure connection: 160 * 86 * 37 incl. silicone protective cover, pressure connection: length 11mm	Weight	approx. 250 g incl. battery and cover	Non-breakable ABS housing, incl. silicone protective cover								
Protection class	IP65 / IP67														
Dimensions L*W*H [mm]	Without pressure connection: 160 * 86 * 37 incl. silicone protective cover, pressure connection: length 11mm														
Weight	approx. 250 g incl. battery and cover														
Power supply <table border="1" style="width: 100%; border-collapse: collapse;"> <tr> <td style="width: 20%;">Current consumption</td> <td>0.9 mA (for Out = oFF, equivalent to 1000 h), backlight ~10mA (auto-off)</td> </tr> <tr> <td>Battery indicator</td> <td>5 stage battery state indicator , Change battery display for exhausted battery: "bAt", warning: "bAt" flashing</td> </tr> </table>	Current consumption	0.9 mA (for Out = oFF, equivalent to 1000 h), backlight ~10mA (auto-off)	Battery indicator	5 stage battery state indicator , Change battery display for exhausted battery: "bAt", warning: "bAt" flashing	2*AAA batteries is (included in scope of supply) or external										
Current consumption	0.9 mA (for Out = oFF, equivalent to 1000 h), backlight ~10mA (auto-off)														
Battery indicator	5 stage battery state indicator , Change battery display for exhausted battery: "bAt", warning: "bAt" flashing														
Auto-off function	Device will be automatically switched off if no key is pressed/no interface communication takes place for the time of the power-off delay. The power-off delay can be set to values between 1 and 120 min.; it can be completely deactivated.														
Directives and standards	<p>The device confirm to following European directives:</p> <table style="width: 100%; border: none;"> <tr> <td style="width: 50%;">2014/30/EU</td> <td>EMV directive</td> </tr> <tr> <td>2011/65/EU</td> <td>RoHS</td> </tr> <tr> <td>2014/68/EU</td> <td>DGRL</td> </tr> </table> <p>According to the pressure equipment directive 2014/68/EU for gasses of fluid group 2 the device fulfills the conformity assessment procedure corresponding article 4, paragraph 3. According to this no declaration in the EU conformity is needed.</p> <p>Applied harmonized standards:</p> <table style="width: 100%; border: none;"> <tr> <td style="width: 50%;">EN 61326-1:2013</td> <td>Emission level: Class B</td> </tr> <tr> <td></td> <td>EMI immunity according to table 3</td> </tr> <tr> <td></td> <td>Additional fault during perturbation: < 0.5 % FS</td> </tr> <tr> <td>EN 50581:2012</td> <td></td> </tr> </table> <p>The device is for the mobile application or for the stationary operation in the course of specified working conditions without further restrictions construed.</p>	2014/30/EU	EMV directive	2011/65/EU	RoHS	2014/68/EU	DGRL	EN 61326-1:2013	Emission level: Class B		EMI immunity according to table 3		Additional fault during perturbation: < 0.5 % FS	EN 50581:2012	
2014/30/EU	EMV directive														
2011/65/EU	RoHS														
2014/68/EU	DGRL														
EN 61326-1:2013	Emission level: Class B														
	EMI immunity according to table 3														
	Additional fault during perturbation: < 0.5 % FS														
EN 50581:2012															