

MINI DIAPHRAGM VACUUM PUMP

LABOPORT® N 96



Technical features

- 100% oil-free transfer – thereby pure transferring, evacuation and compression of gases
- Extremely low footprint
- PTFE-coated diaphragm is ideal for aggressive/ corrosive gases and vapors
- Integrated rotational speed control
- Environmentally friendly
- Start against ultimate vacuum of the pump

Technical data

Flow rate [m ³ /h] at atm. pressure	0.4
Flow rate [l/min] at atm. pressure	7
Ultimate vacuum [mbar abs.]	<130
Operating pressure [bar]	2.5
Voltage pump [V]	24 DC
Protection class	IP40
Power P ₁ [W]	19
Operating current pump [A]	≈ 0.9
Voltage power-supply unit [V]	100 – 240 AC
Frequencies power-supply unit [Hz]	50/60
Operating current power-supply unit [A]	0.4 (230 V AC) 0.7 (100 V AC)

OTHER DATA

Weight [kg]	1.3
Gas connections	NPT 1/8 – hose connector ID6, PP is part of the supply
Dimensions W x H x D [mm]	75 x 119 x 156
Permissible media and ambient temperature [°C]	+5 to +40

ACCESSORIES AND SPARE PARTS

ACCESSORIES AND SPARE PARTS	ID
Spare parts kit	322636
Power-supply unit kit	323457
Silencer and hose connector ID6, PP*	323456
Column fixture	323484

*Part of the scope of delivery

MATERIALS

Pump head	PPS
Diaphragm	PTFE-coated
Valves	FKM

Dimensions

N 96

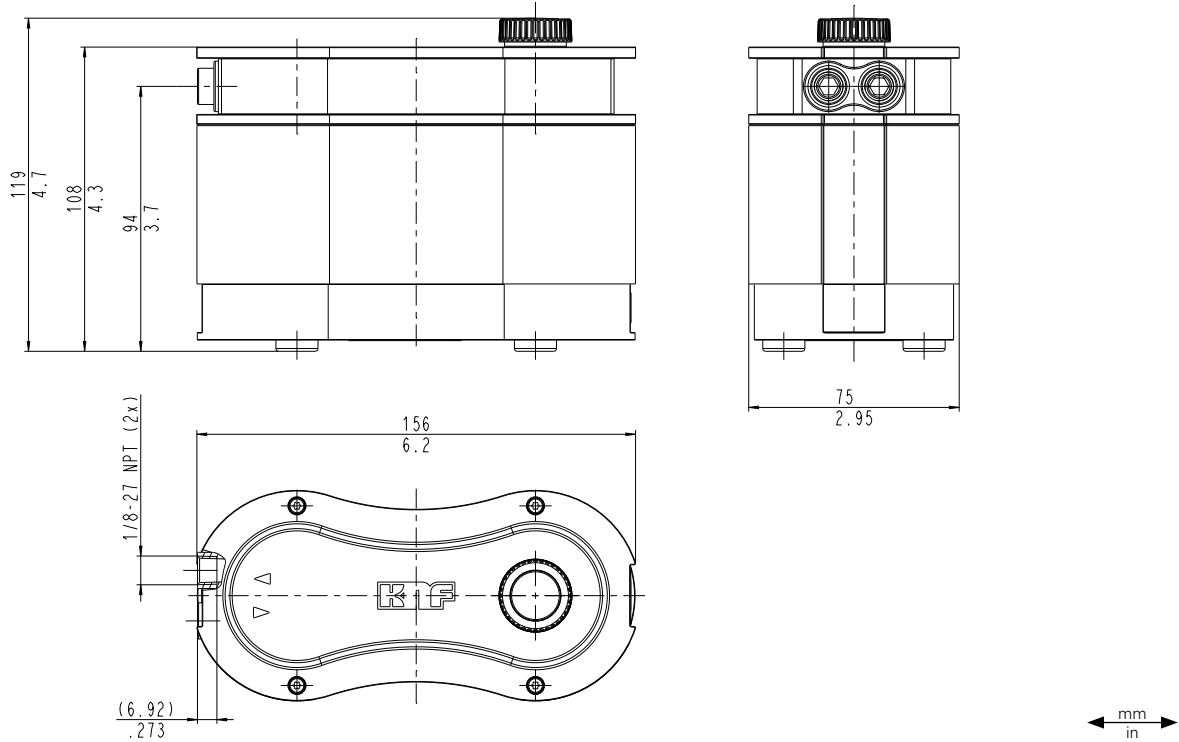

Performance characteristics

PUMP DOWN TIME FOR 5 LITER VESSEL

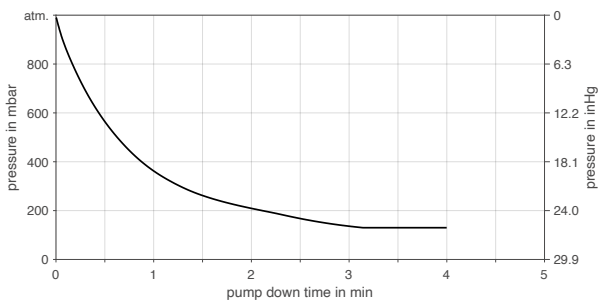

FLOW RATE

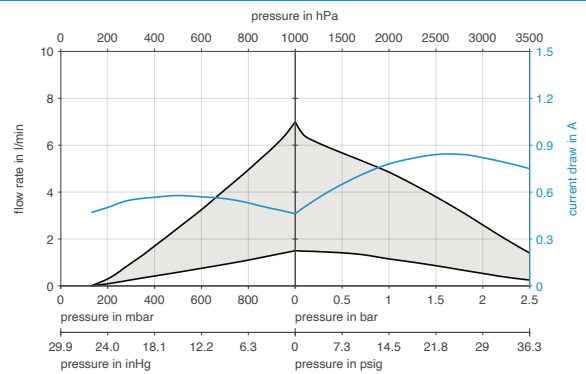

SUCTION PUMPING SPEED AT MIN./MAX. MOTOR SPEED

